

TECHNICAL DATA

Three Phase Electric Motors - Cast Iron Frame
 PE30 112 M 4 IE3
 4 kW / 5.5 Cv
 1460 RPM

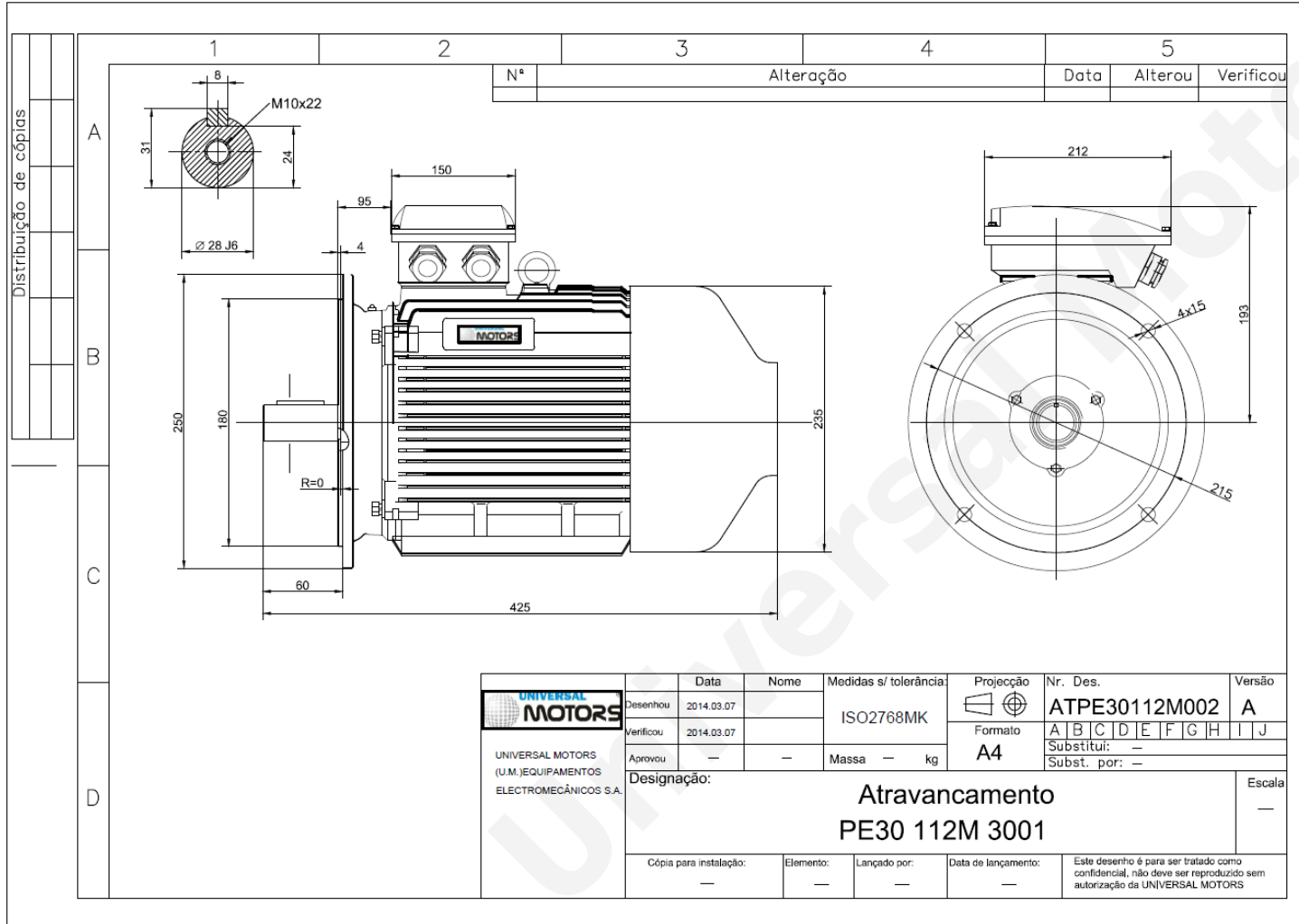

Motor type:	PE30 112 M 4 IE3
Output:	4 kW / 5.5 Cv
Speed (min ⁻¹):	1460 RPM
Frequency:	50 Hz
Voltage:	400 V
Current:	7.95 A
Power factor (Cos Ø):	0.82
Poles:	4
Insulation class:	F
Temperature rise Class:	B
Efficiency 50%:	87.9 %
Efficiency 75%:	89.4 %
Efficiency 100%:	88.7 %
Torque:	26 N.m
Tstarting/Tnominal:	2.2
Istarting/Inominal:	7.8
Tmaximum/Tnominal:	2.3
Noise:	54 Db(A)
Weight:	61 Kg
Bearing DE:	6306 2Z C3
Bearing NDE:	6306 2Z C3

Regime - S1

Altitude - 1000m

Environment Temperature - 40°C

CONTACTS:

UNIVERSAL MOTORS Tel: +351 252 299 080
 Rua de São Brás,745 Fax: +351 252 299 089
 4480-782 VILA DO CONDE Mail: geral@universalmotors.pt

* References applied only in the UK